

Prizelawn® CBR III

COMMERCIAL BROADCAST SPREADER

MODEL CBR III
MODEL CBR III SS

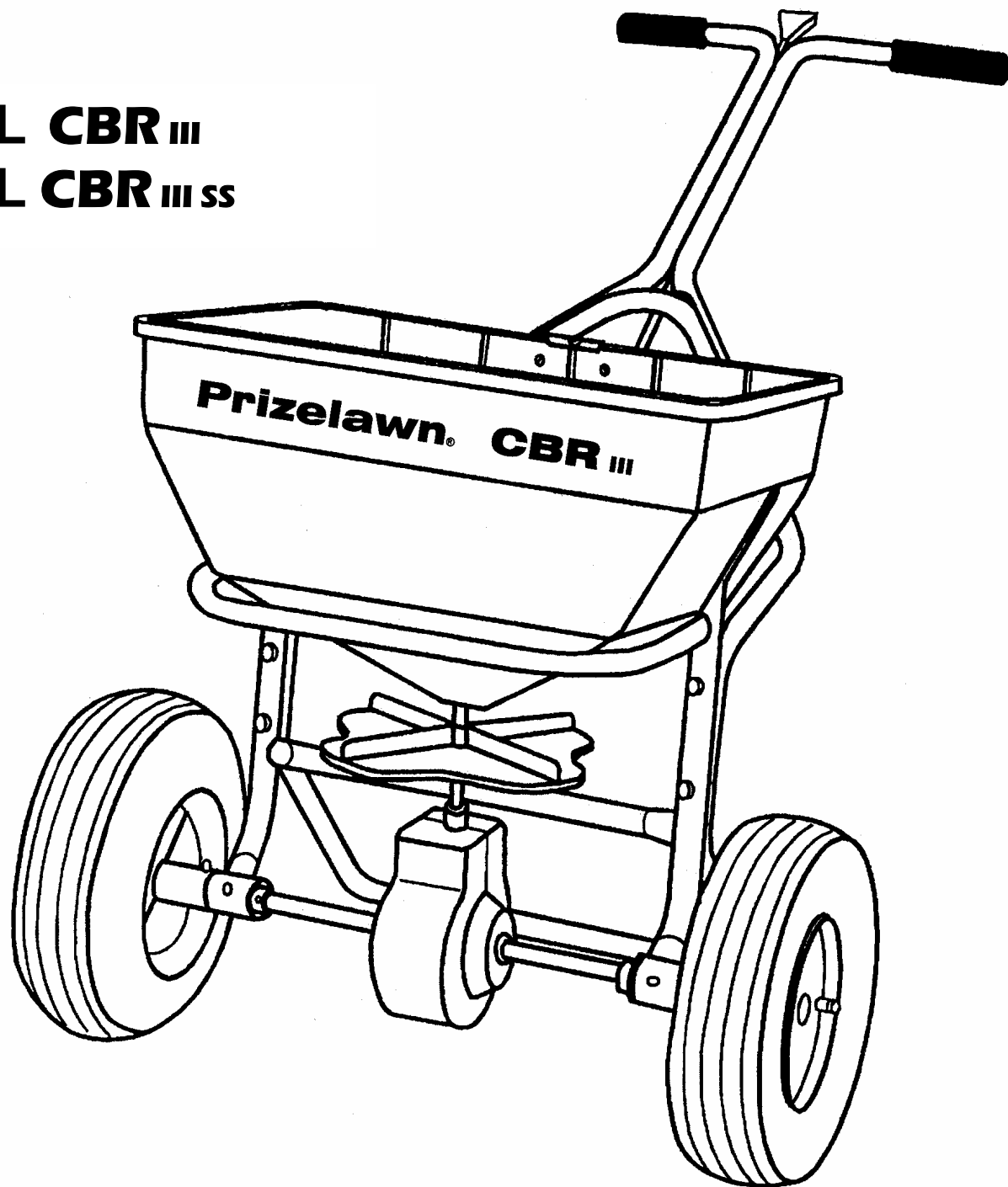

OWNER'S MANUAL

ASSEMBLY

1. Remove the spreader and components from carton and place hopper up-side down on a padded surface as shown. Insert ends of leg into handle brace as shown and align holes. Attach brace and leg to frame using (4) 1/4-20 x 2" hex bolts, lockwashers, and nuts.

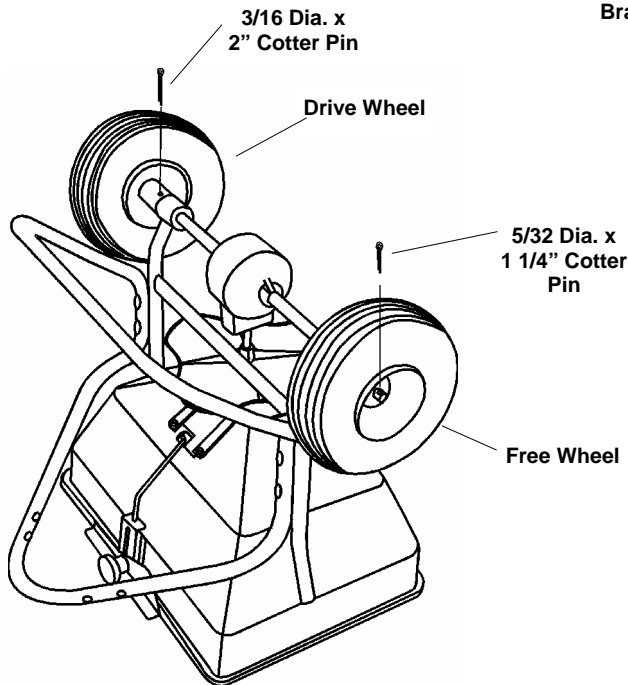
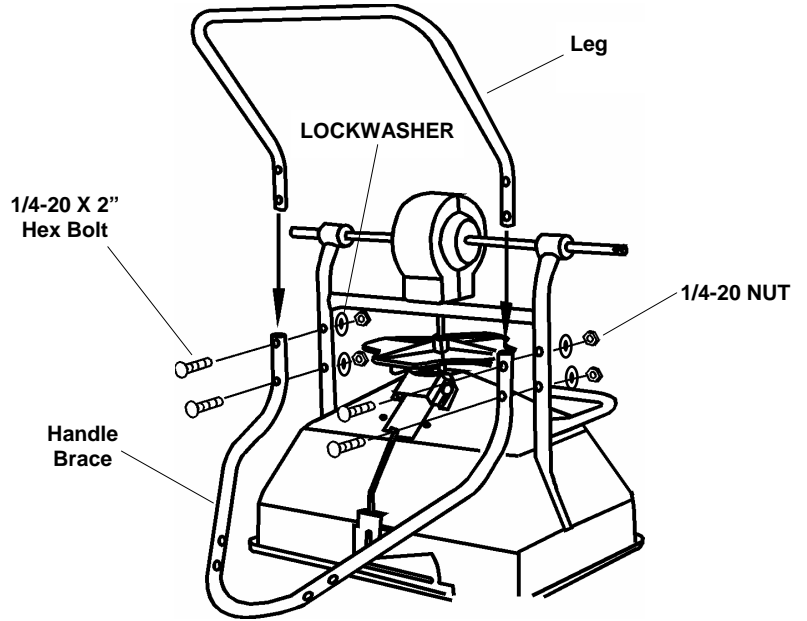

2. Slide drive and free wheel onto axle as shown with the longer portion of wheel hub facing the frame. Secure free wheel with (1) 5/32 dia. x 1 1/4" cotter pin. Attach drive wheel to axle with (1) 3/16 dia. x 2" cotter pin.

3. Turn spreader upright on wheels. Insert screen into hopper sliding it under the screen clips. Attach the upper handle assembly to handle brace with the handle lever brackets facing as shown. Secure with (4) 1/4-20 x 1 1/2" hex bolts, lockwashers and nuts.

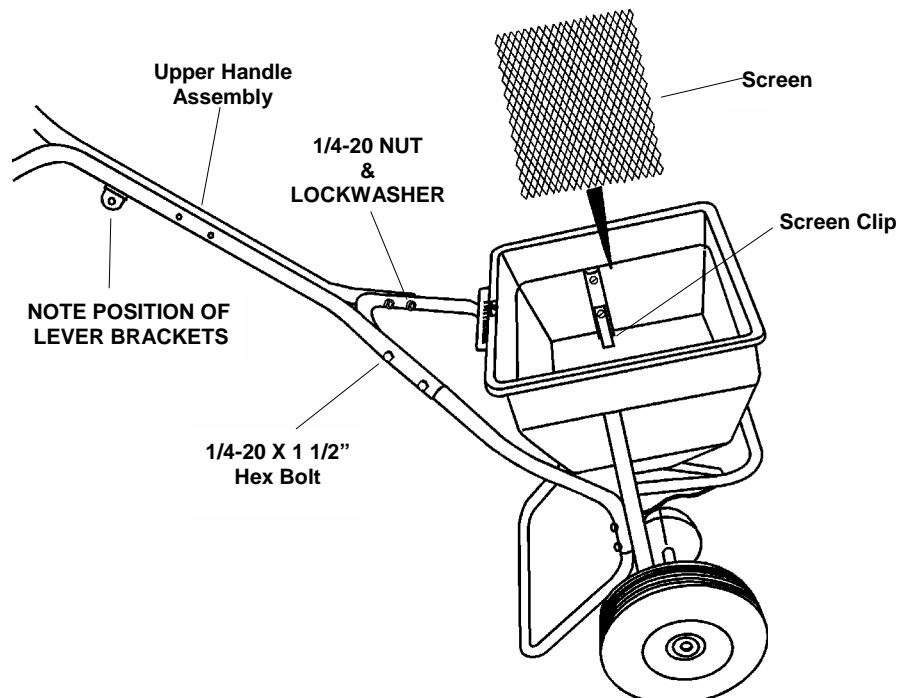

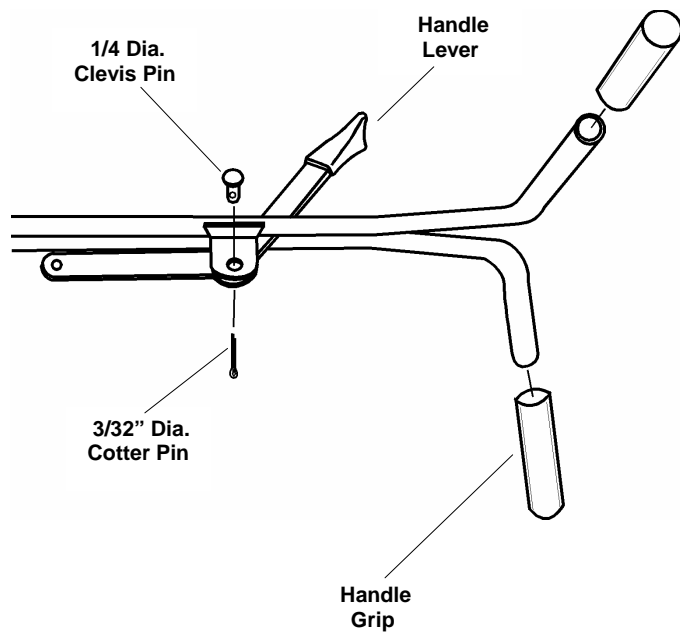

4. Slide handle lever between handle brackets as shown and secure with (1) 1/4 dia. clevis pin and 3/32" dia. cotter pin. Make sure lever pivots freely. Install handle grips onto upper handle.

5. Install control tube to handle lever with (1) 1/4 dia. clevis pin and a 3/32" dia. cotter pin. Slip opposite end of control tube over lower control rod making sure shutoff plate is between the lower rod and the control tube. Secure with a 3/32" dia. cotter pin.

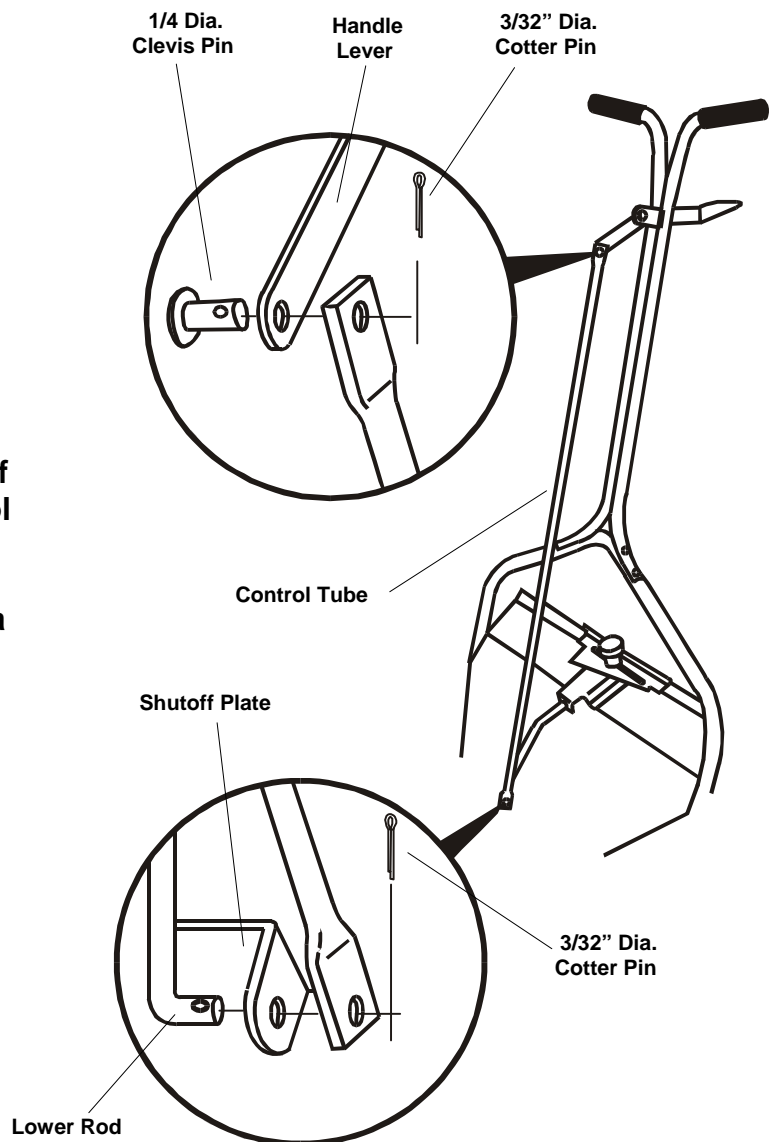

OPERATION

1. Check the product package for the rate setting, and recommended swath width. Loosen rate control knob and slide rate plate to the proper setting. The pattern is controlled by loosening the two knobs on the discharge chute and moving the chute closer or farther away from the impeller (setting A, B, or C). See “PATTERN ADJUSTMENT” for details.

2. Always fill the spreader on the driveway or sidewalk-not on the lawn. Make sure screen is in hopper and spreader is in the “OFF” position.

3. Start spreader moving before opening port. Close before stopping. Always push spreader, never pull.

4. Hold handle so top of spreader is level. Tipping the spreader too far can cause uneven spreading.

5. The settings and swath widths on the product label are recommended starting points. Always check the delivery rate and pattern on a small area before treating a large area. Actual delivery rate can vary due to weather conditions, operating variables, and condition of the product being applied. See “HOW TO DETERMINE SPREADER SETTINGS AND SPREAD WIDTH” for details.

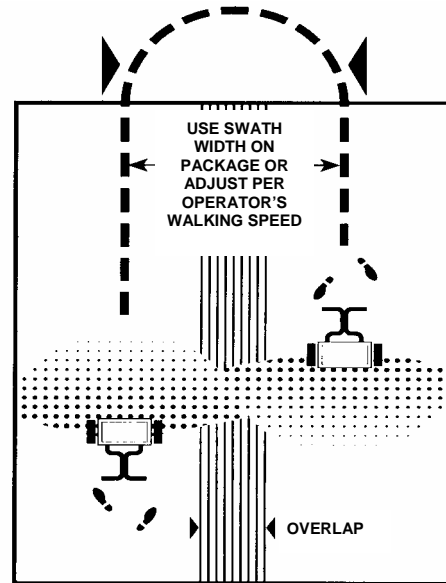

6. Push spreader at a normal walking speed - 2 1/2 m.p.h. (18 feet in 5 seconds). Apply header strips around area to be treated. Space trips across the area as shown. Keep material off flower beds, sidewalks, etc.

7. When transporting spreader, make sure that it is in the “OFF” position. Make sure handle lever is locked using the hitch pin through the hole in lever.

8. Empty spreader after each use. Return leftover material to its original container.

PATTERN ADJUSTMENT

Normal spreading of materials requires no adjustment (factory setting “A”) unless stated on the package. In those cases where the spread pattern has shifted, the pattern can be adjusted left and right by loosening the two knobs on the discharge chute and moving the chute closer or farther away from the impeller. Settings of “A, B, and C” are provided as reference.

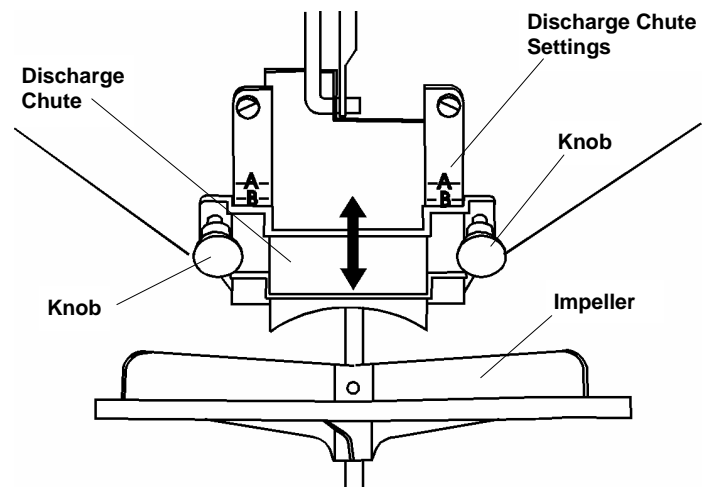

HOW TO DETERMINE SPREADER SETTINGS AND SPREAD WIDTH

Two major factors should be considered when determining correct spreader settings of any product:

1. The product application rate, or the amount of material applied per 1,000 square feet.
2. The effective pattern width, or the actual width in which material is applied. Label settings are a guide and can be affected by numerous factors.

EFFECTIVE PATTERN WIDTH

A simple visual pattern test can be made by operating the spreader over a non-turf area and evaluating the pattern. A more accurate method is to place a row of common, disposable, aluminum cake pans approximately 1 foot on centers. Set the rate plate at a middle setting and make 3 or 4 passes in the same direction as shown. Pour the material collected from each pan into individual bottles of the same size. Set them side by side in order, and visually inspect their volume. If the pattern is not centered (example: volume in bottle #2 left not equal to bottle #2 right), adjust the discharge chute up or down as described in "PATTERN ADJUSTMENT" section.

Once the pattern is uniform, the effective pattern width can be determined. The

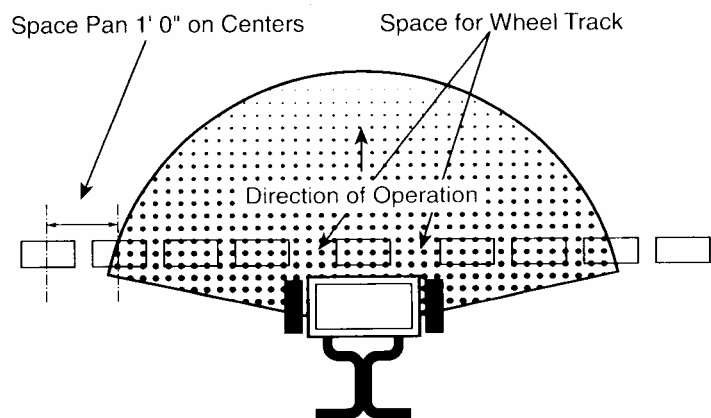

effective pattern width is the distance out from the spreader to a point where the amount of material is 1/2 the average amount in the center pans. This distance is multiplied by 2 to achieve the total effective pattern width.

APPLICATION RATE

Knowing the effective pattern width (for example, 10 feet), measure a distance equal to 100 square feet (10' x 10' swath width). Determine the product coverage in pounds / 100 sq. ft. by taking the weight of the product and dividing it by the recommended square foot coverage (add two zeroes to the weight of the bag).

EXAMPLE: Product weight: 25 lbs.
sq. ft. coverage: 5,000 sq. ft.
2500 lbs. - 5,000 sq. ft.
= .5 lbs. / 100 sq. ft.





Weigh out 15 to 20 lbs. of material and spread over the 100 sq. ft. area. Weigh remaining material left in hopper and adjust rate setting as required. Repeat test until application rate is correct.

RATE SETTING CONVERSION

The following provides approximate **Prizelawn® CBR III/ CBR III ss** settings for those units listed.

Prizelawn. CBR III/ CBR III ss Setting	B	C	D	E	F	G	H	I	J	K	L	M	N	O	P	Q	R	S	T	U	V	W	X	Y	Z
Prizelawn. BF I/ BF I ss Setting	B	C	D	E	F	G	H	I	J	K	L	M	N	O	P	Q	R	S	T	U	V	W	X	Y	Z
Prizelawn. CBR II Setting	—	2	—	2.5	—	3	3.5	—	4	—	4.5	5	5.5	6	6.5	7	8	9.5	10	11	12	13	14	15	—
Lesco #029600 Setting	—	B	C	D	—	E	F	—	G	H	I	—	J	K	L	—	M	N	O	—	P	Q	R	—	S
Scotts R8A/SR-1 Setting	D	E	F	G	H	I	J	K	L	M	N	O	P	Q	R	S	T	U	—	V	W	—	X	Y	Z
Earthway 2200/2400 Setting	5	—	—	—	10	—	—	—	—	15	—	—	—	—	20	—	—	—	—	25	—	—	—	—	30
Spyker 76/78-2 Setting	—	3	—	—	—	4	—	—	5	—	—	6	—	—	7	—	—	8	—	—	—	9	—	—	10

The following provides approximate **Prizelawn® CBR III/ CBR III ss** settings when only the product weight, square foot coverage, and visual inspection of the material is available.

FERTILIZER PARTICLE SIZE	BAG RATE Pounds of fertilizer used per 1,000 sq. ft. of coverage	APPROX. SETTING	SPREAD WIDTH (IN FEET)
Large, heavy particles 	5	M	8
	10	O	8
	15	Q	8
Medium- mixed particles 	5	L	8
	10	N	8
	15	O	8
Small particles (nitrogen) 	1	G	8
	2	J	8
	3	L	8
Mixed size particles -some fines 	5	M	6
	10	O	6
	15	P	6
Light weight particles 	5	J	4
	10	L	To
	15	O	6

The conversions should be used as guidelines for establishing proper rate settings for the particular product being applied. Steps for obtaining the most accurate settings are outlined in the “How to Determine Spreader Settings and Spread Width” section of this manual.

These settings are approximate and may vary due to physical characteristics of the product. Walking speed, wear, condition of the turf and humidity, may cause actual rate setting to deviate. No expressed nor implied warranty or guarantee is provided as to coverage or uniformity indicated by these rate settings.

RATE

OLD STYLE





SETTING

The following

provides

PrizeLAWN® CBR III Setting	B	C	D	E	F	G	H	I	J	K	L	M	N	O	P	Q	R	S	T	U	V	W	X	Y	Z
PrizeLAWN BigFOOT® Setting	B	C	D	E	F	G	H	I	J	K	L	M	N	O	P	Q	R	S	T	U	V	W	X	Y	Z
PrizeLAWN® CBR II Setting	—	2	3	4	—	5	6	—	7	8	9	—	10	11	12	—	13	14	15	—	16	—	17	18	—
Lesco #029600 Setting	—	B	C	D	—	E	F	—	G	H	I	—	J	K	L	—	M	N	O	—	P	Q	R	—	S
Scotts R8A/SR-1 Setting	D	E	F	G	H	I	J	K	L	M	N	O	P	Q	R	S	T	U	V	W	X	Y	Z	—	—
Earthway 2200/2400 Setting	5	—	—	—	10	—	—	—	—	15	—	—	—	—	20	—	—	—	—	25	—	—	—	—	30
Spyker 76/78-2 Setting	—	3	—	—	—	4	—	—	5	—	—	6	—	—	7	—	—	8	—	—	—	9	—	—	10

The following provides approximate **Prizelawn® CBR III** settings when only the product weight, square foot coverage, and visual inspection of the material is available.

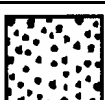
FERTILIZER PARTICLE SIZE		BAG RATE Pounds of fertilizer used per 1,000 sq. ft. of coverage	APPROX. SETTING	SPREAD WIDTH (IN FEET)
Large, heavy particles		5	G	8
		10	H	8
		15	J	8
Medium- mixed particles		5	F	8
		10	G	8
		15	H	8
Small particles (nitrogen)		1	D	8
		2	E	8
		3	F	8
Mixed size particles -some fines		5	F	6
		10	G	6
		15	I	6
Light weight particles		5	E	4
		10	F	To
		15	H	6

The conversions should be used as guidelines for establishing proper rate settings for the particular product being applied. Steps for obtaining the most accurate settings are outlined in the “How to Determine Spreader Settings and Spread Width” section of this manual.

These settings are approximate and may vary due to physical characteristics of the product. Walking speed, wear, condition of the turf and humidity, may cause actual rate setting to deviate. No expressed nor implied warranty or guarantee is provided as to coverage or uniformity indicated by these rate settings.

MAINTENANCE

1. Never store unused material in spreader. Return unused product to its original container.
2. Wash spreader thoroughly after each use and dry completely in sun or heated area.
3. Grease axle bearings in frame. Oil the impeller shaft bearing in hopper, pivot points on the shut-off plate and the spring in the housing behind the rate plate.
4. Remove gear cover and wash gears thoroughly. Oil all bearing areas and face of gear teeth. Lubricate gear teeth with dry graphite. Re-install gear cover.
5. Gear mesh should be checked on a regular basis during high use periods. Clearance between the axle gear and pinion gear should be minimal but not tight. If adjustment is necessary, loosen axle collar set screw and hold gears together. Slide axle collar against the gear support and tighten axle collar set screw. Spin drive wheel. Gears should run freely and smoothly.
6. Impeller surface should be cleaned periodically to remove build-up of product. Build-up can cause the spread pattern to change.
7. Tire pressure should be 20-25 PSI.

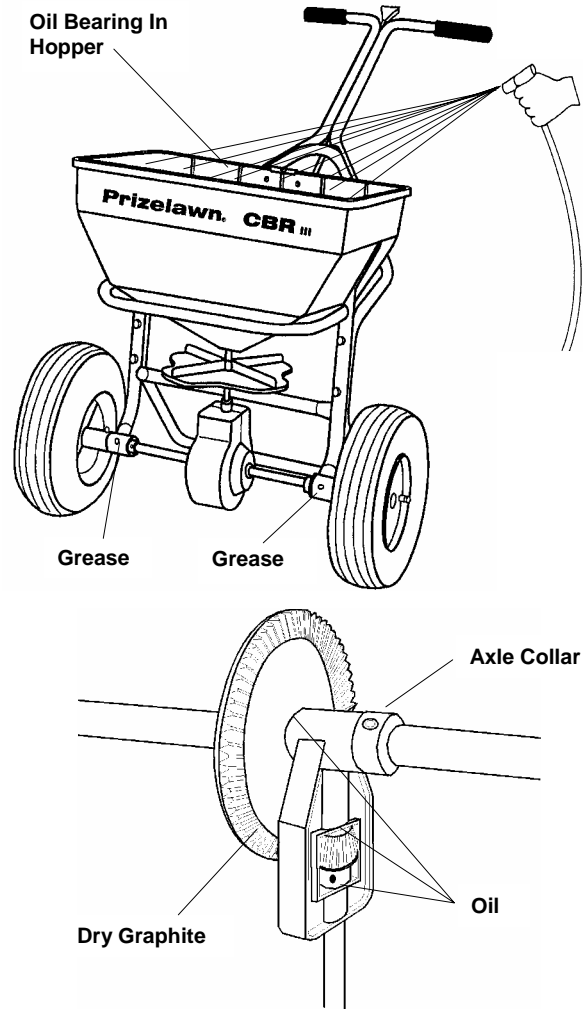

CALIBRATION INSTRUCTIONS

The **Prizelawn® CBR III** was factory calibrated, however, calibration should be checked occasionally to assure optimum performance.

1. Pull the on/off lever to the "OFF" position. Set the rate control plate to setting "B".

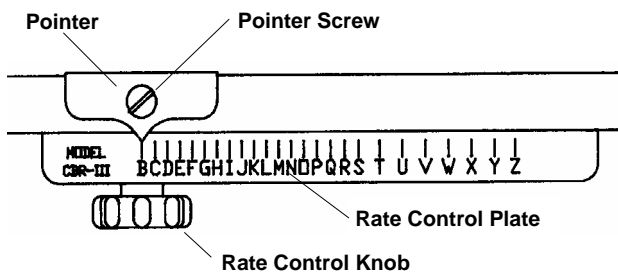

2. Flip on/off control lever to the "ON" position. Check the port opening. It should be just open. If adjustment is necessary, continue to step #3.

3. Loosen the rate control knob and slide the rate plate until the port is just opening. Loosen pointer screw and move pointer until it aligns with "B" on the rate plate. Retighten pointer screw.

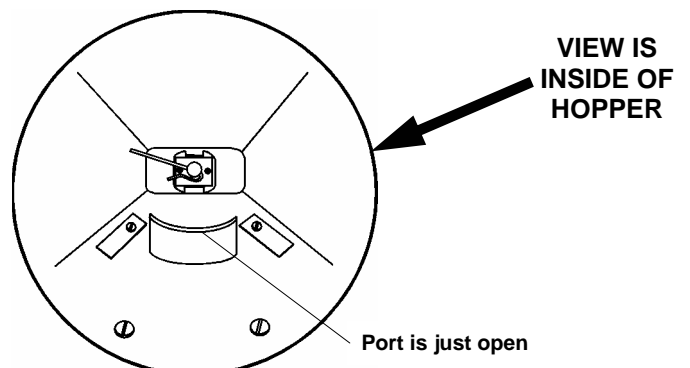

Parts List For Model CBR III / CBR III ss

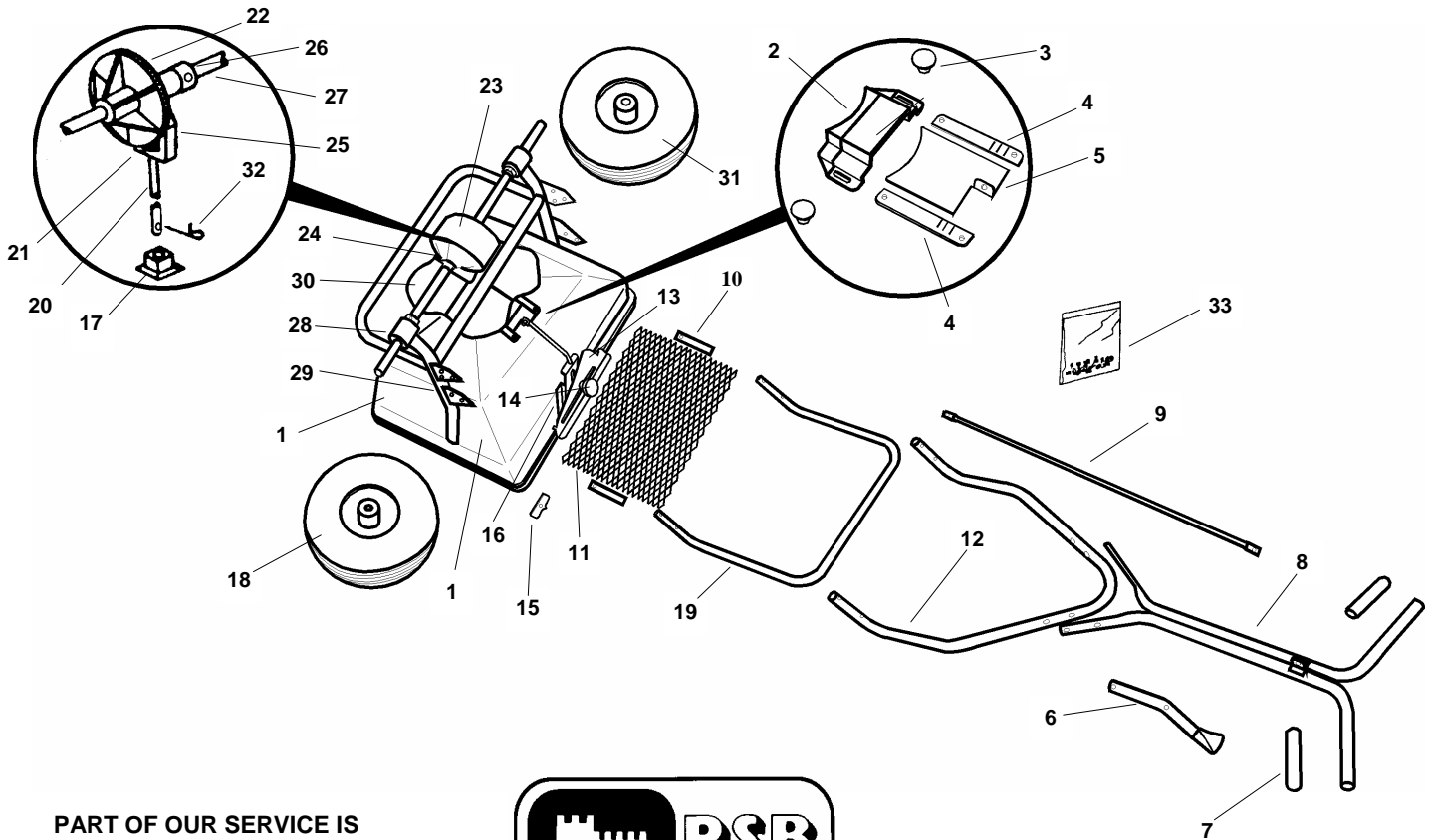

PART OF OUR SERVICE IS PROVIDING REPLACEMENT PARTS. Parts may be obtained through your local distributor. Be sure to give:

1. SPREADER MODEL NUMBER
2. SPREADER NAME
3. PART NUMBER
4. NAME OF PART AS SHOWN



IF YOUR LOCAL DISTRIBUTOR CANNOT SUPPLY PARTS, CONTACT:

PSB Company

555 West Goodale Street P.O. Box 1089

Columbus, Ohio 43216-1089

614-228-5781 EXT. 2655

No.	Description	CBR III	CBR III ss	No.	Description	CBR III	CBR III ss
1	Hopper Assembly	14610-2	14610-2	17	Impeller Shaft Bearing*	14312-1	14312-1
1A	Hopper*	14604	14604	18	Drive Wheel	15032	15032
2	Discharge Chute*	14623	14623	19	Leg	15007-1	15189
3	Discharge Chute Knob (2)*	14001	14001	20	Impeller Shaft	15036	15036
4A	Shutoff Plate Guide-RH.*	14622	14622	21	Pinion Gear	14833	14833
4B	Shutoff Plate Guide-LH.*	14621	14621	22	Axle Gear	15027	15027
5	Shutoff Plate*	13353	13353	23	Gear Cover (2)	15012	15012
6	Handle Lever Ass'y w/ Chain	14047	14047	24	Gear Cover Clamps (3)	14868	14868
7	Handle Grip (2)	14870	14870	25	Gear Support	15028	15028
8	Upper Handle	14825-1	14907	26	Axle Collar w/ Set Scr.	14063	14063
9	Control Tube	14871	14916	27	Axle	15037	15037
10	Screen Clips (2)	14022	14022	28	Axle Bearing (4)	14933	14933
11	Hopper Screen	14603	14603	29	Frame Assembly	15038	15184
12	Handle Brace	15011-1	15188	30	Impeller	14625	14625
13	Rate Plate*	14932	15191	31	Free Wheel	15033	15033
14	Rate Control Knob*	12704	12704	32	Agitator	14510	14510
15	Pointer*	12708	12708	33	Fastener Package	15035-1	15035-1
16	Spring Housing Assembly*	12702-2	12702-2				

*Parts included in hopper assembly

© 2003 PSB COMPANY